

TITAN LEAF PRO PLUS

EQUIPMENT FEATURES:

- Dual safety interlock system on intake nozzle & belt guard
- DOT compliant lighting and markings
- 5 - belt drive system with 30" fan
- 12 Volt battery
- 99 hp diesel-powered engine from Kubota® or John Deere®
- 7,000 - pound axle with electric trailer brakes
- 14,000 - pound 3" adjustable pintle eye with safety chain
- 35 or 50 gallon fuel tank
- Manual jack
- 16" diameter pickup hose with 3 - function hydraulically controlled pickup arm



Shown with options

Titan LEAF PRO +™

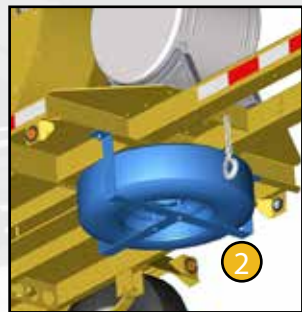

OPTIONS

- 1 85 - 99 hp Kubota® or John Deere® engine
- 2 Spare tire
- 3 35 or 50 U.S. gallon fuel tank
- 4 Electric over hydraulic valve controls
- 5 32" diameter fan
- 6 Proportional controls for collection nozzle
- 7 Trans-fluid coupler in lieu of standard clutch
- 8 Ride on seat / swivel caster wheel for jack
- 9 Fixed or manual swivel discharge nozzle
- 10 Wire pendent for walk-beside control
- 11 Left - side collection nozzle build
- 12 Wireless control box
- 13 Hydraulic jack with swivel caster wheel
- 14 Direct wired control into cab of truck
- 15 Directional light bar / L.E.D. flashers
- 16 Closed circuit camera system
- 17 Dust control system (if equipped) 100 U.S. gallons

SPECIFICATIONS

Weight, Base Model..... 6,200 lbs.
Fuel Tank, Aluminum..... 35 U.S. gallons
Hydraulic Tank Only 7 U.S. gallons
Engine..... 99 hp Kubota
Collection Nozzle..... Right-side
Parking Jack..... Manual
Battery..... 12 Volt, 1190 Amp; 950 CCA
Axle..... 7,000 lb. with electric brakes
Tires..... ST235/80R16, load range E
Fan..... 30" diameter
Belts (five)..... 5VX

Titan LEAF™
 SOLUTIONS

www.bonnell.com • (800) 851-9664 • info@bonnell.com
 1385 Franklin Grove Rd. • Dixon, IL 61021



CERTIFIED TITAN DEALER: